



US 20040207321A1

(19) **United States**

(12) **Patent Application Publication** (10) **Pub. No.: US 2004/0207321 A1**

**Nishikawa et al.**

(43) **Pub. Date: Oct. 21, 2004**

(54) **ELECTROLUMINESCENT DISPLAY DEVICE**

**Publication Classification**

(75) Inventors: **Ryuji Nishikawa**, Gifu-shi (JP);  
**Kazuyuki Maeda**, Nishikasugai-gun (JP)

(51) **Int. Cl.<sup>7</sup> ..... H01J 1/62**

(52) **U.S. Cl. .... 313/506**

Correspondence Address:  
**MORRISON & FOERSTER LLP**  
**1650 TYSONS BOULEVARD**  
**SUITE 300**  
**MCLEAN, VA 22102 (US)**

(57) **ABSTRACT**

The invention is directed to an electroluminescent display device in which a first planarization insulating film need not be used so that a manufacturing cost reduces, and a display defect caused by a cut in an organic EL layer or moisture absorption at a step portion is prevented. An R color filter layer, a G color filter layer, and a B color filter layer are so formed that end portions of the adjacent R, G, and B color filter layers overlap each other. The R color filter layer, the G color filter layer, and the B color filter layer serve as a first planarization insulating film. For planarization, the end portions of the color filter layers overlap each other. For reducing a step height of an overlapping portion, the end portions of the color filters are formed in a tapered shape.

(73) Assignee: **Sanyo Electric Co., Ltd.**, Moriguchi-city (JP)

(21) Appl. No.: **10/758,596**

(22) Filed: **Jan. 16, 2004**

(30) **Foreign Application Priority Data**

Jan. 21, 2003 (JP) ..... 2003-012380

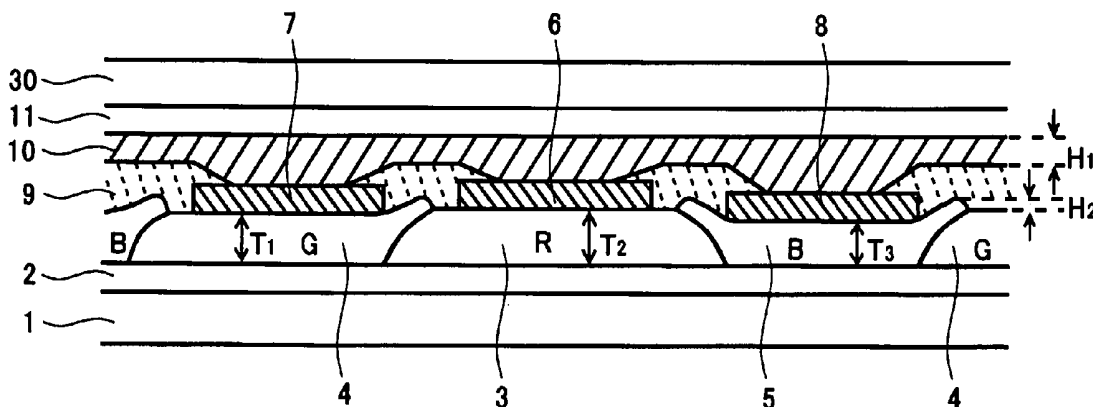

FIG. 1

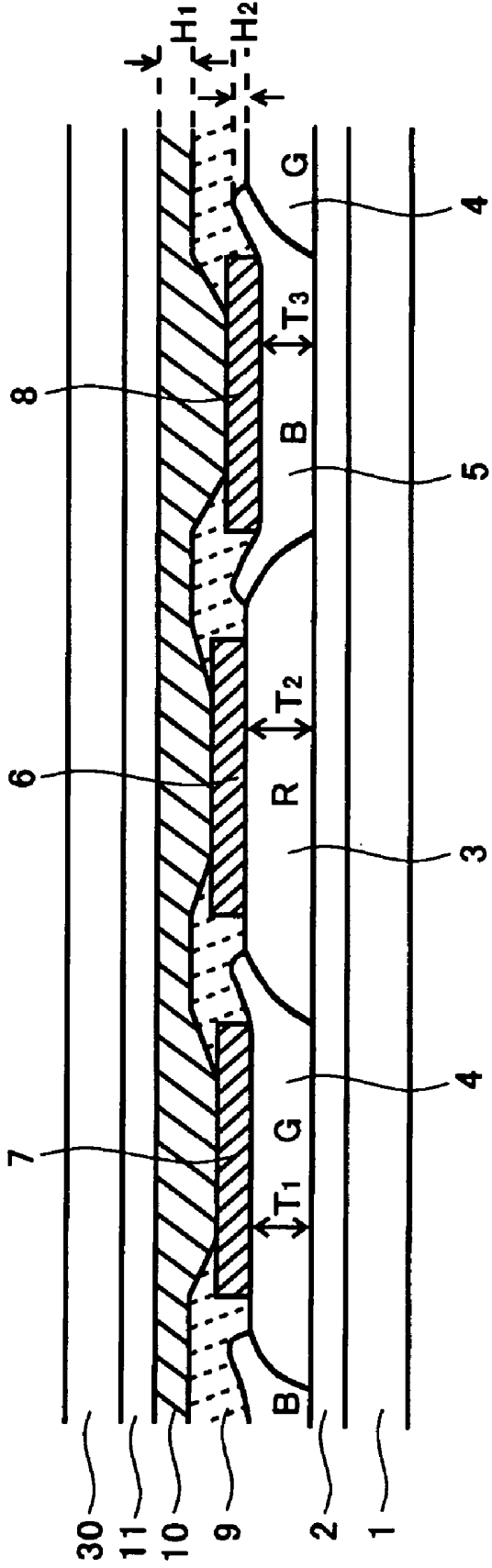

FIG.2A

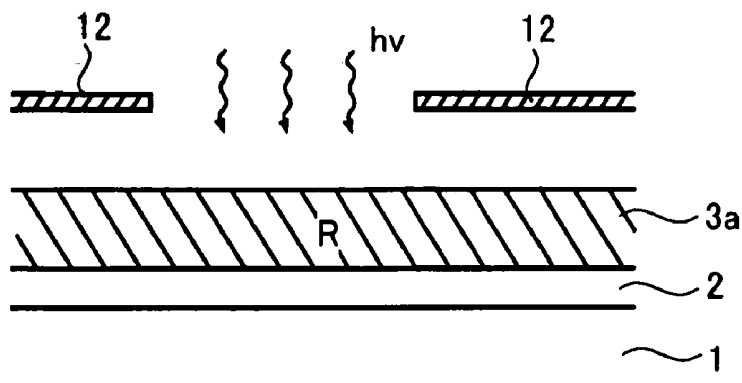

FIG.2B

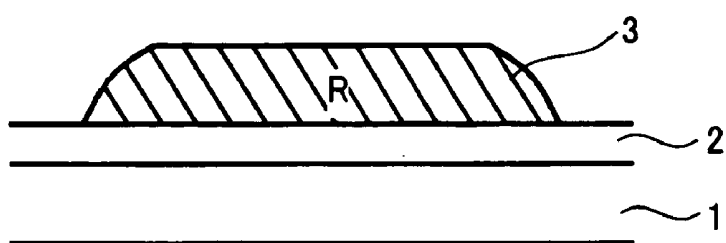

FIG.2C

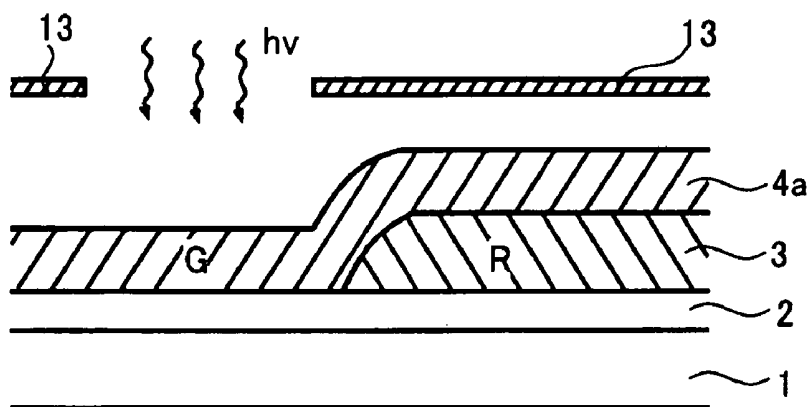

FIG.2D

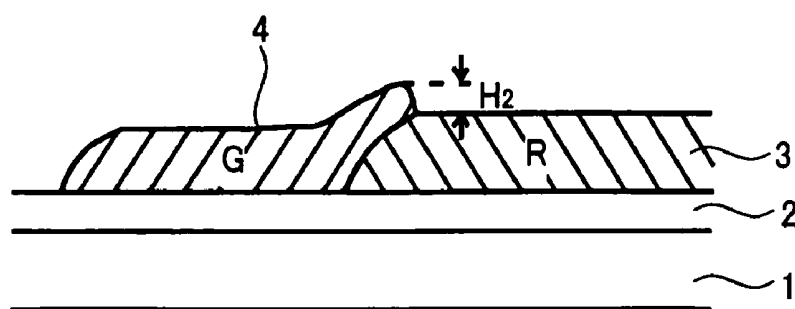
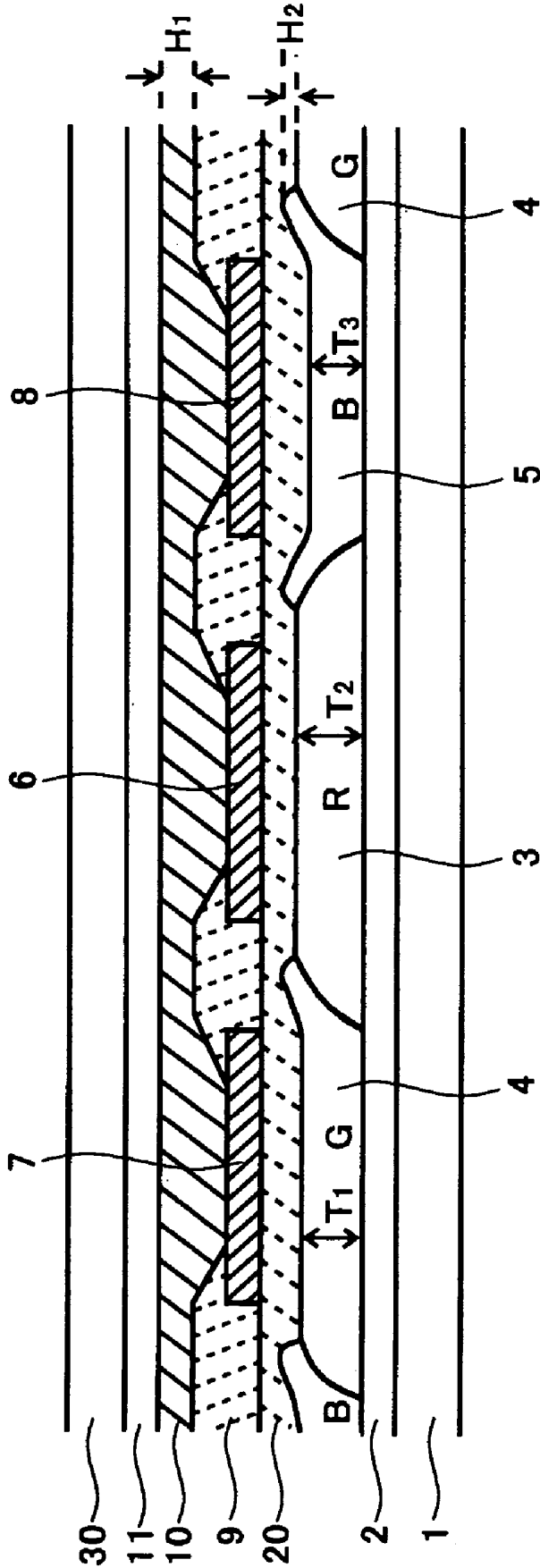
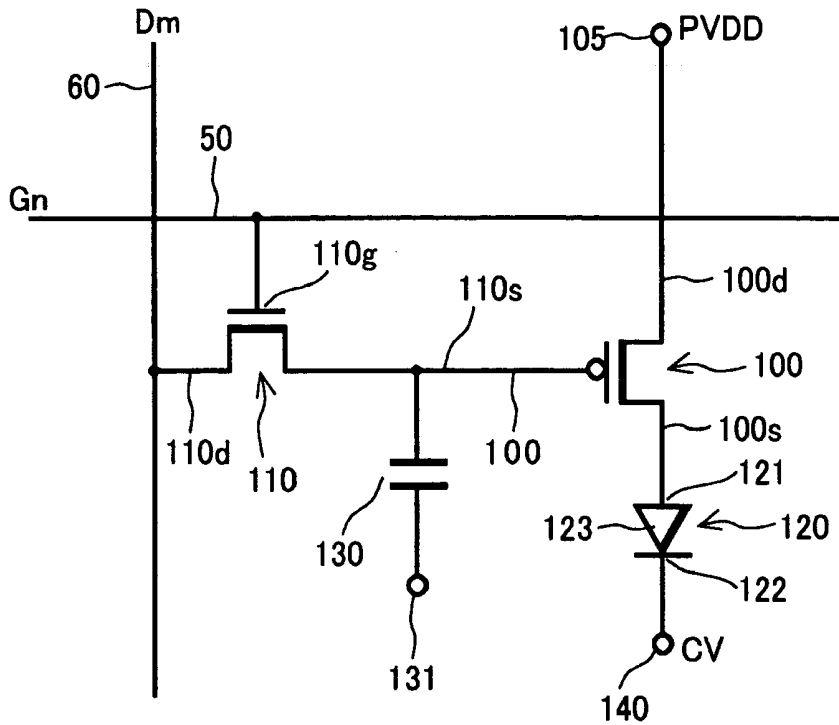

FIG.3

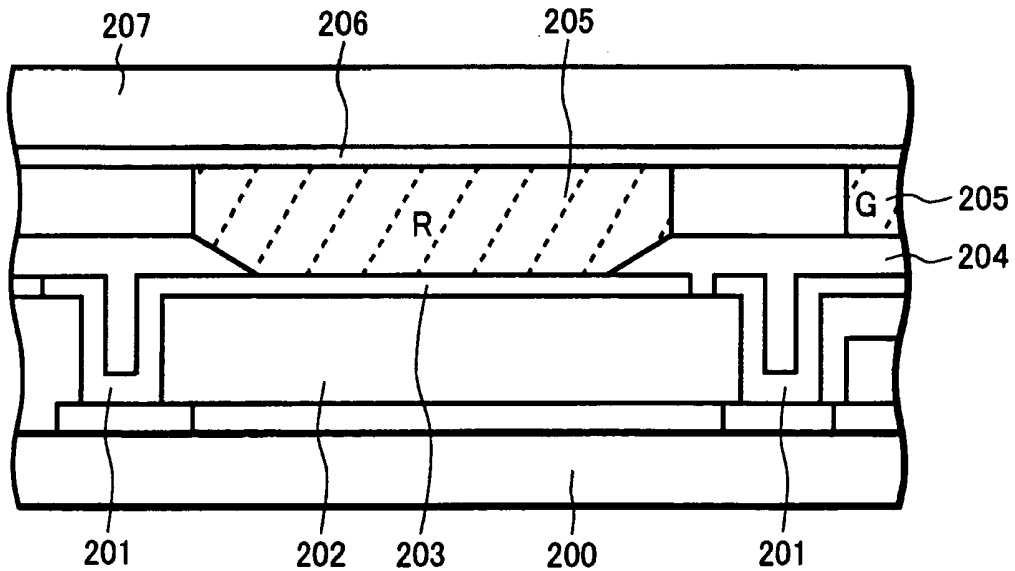

**FIG. 4**



**FIG. 5**

Prior Art



**FIG. 6**

Prior Art

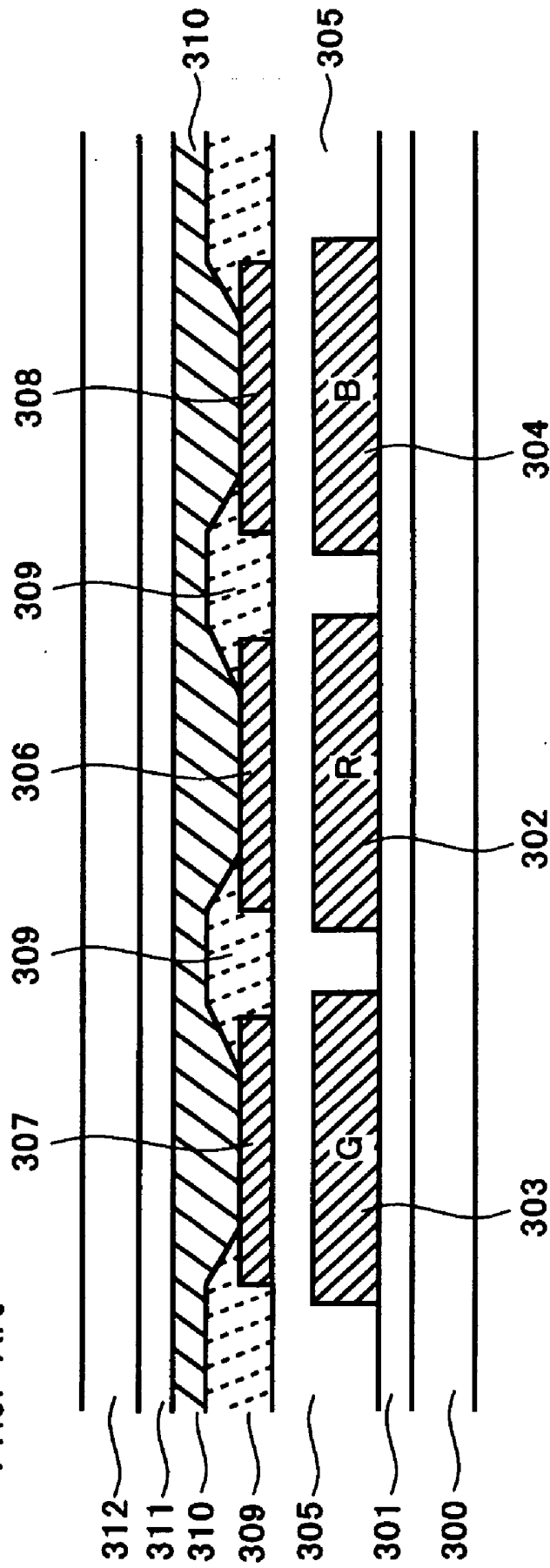

## ELECTROLUMINESCENT DISPLAY DEVICE

## BACKGROUND OF THE INVENTION

[0001] 1. Field of the Invention

[0002] The invention relates to an electroluminescent display device, particularly to an electroluminescent display device having color filter layers.

[0003] 2. Description of the Related Art

[0004] An organic electroluminescent (hereafter, referred to as EL) element is a self-emission element. An organic EL display device using the organic EL element is receiving an attention as a new display device substituted for a CRT or an LCD.

[0005] FIG. 5 is a schematic cross-sectional view showing a pixel of a full-color organic EL display device of the conventional art. A numeral 200 designates a glass substrate, a numeral 201 designates an organic EL element driving TFT (thin film transistor) formed on the glass substrate 200, and a numeral 202 designates a first planarization insulating film. A numeral 203 designates an anode layer made of ITO (indium tin oxide) which is connected with the TFT 201 and extends over the first planarization insulating film 202, and a numeral 204 designates a second planarization insulating film formed so as to cover an end portion of the anode layer 203. A numeral 205 designates R (red), G (green), and B (blue) organic EL layers formed on the anode layer 203, and a numeral 206 designates a cathode layer formed on the organic EL layer 205.

[0006] A glass substrate 207 covers the cathode layer 206. The glass substrate 207 and the glass substrate 200 are attached at their edges, and the R, G, and B organic EL layers 205 are enclosed therein. Here, the R, G, and B organic EL layers 205 are respectively formed by selectively performing vapor-deposition of each of R, G, and B organic EL materials by using a metal mask.

[0007] On the other hand, as a method of realizing a full-color organic EL display device without using the above R, G, and B organic EL layers 205, a method of using color filter layers has been proposed. In this case, a combination of a white organic EL layer and color filter layers is employed.

[0008] FIG. 6 is a cross-sectional view of such a full-color organic EL display device. An insulating layer 301 as a substrate is formed on the glass substrate 300, and an R color filter layer 302, a G color filter layer 303, and a B color filter layer 304 are formed on the insulating film 301. Each of these color filter layers transmit light having a predetermined wavelength corresponding to each of the R, G, and B colors, which is irradiated from the white organic EL layer. Although not shown, an organic EL element driving TFT is formed under these color filter layers 302, 303, and 304 in a manner similar to the TFT 201 of FIG. 5.

[0009] A first planarization insulating film 305 is formed on these color filter layers 302, 303, and 304. Anode layers 306, 307, and 308 are formed on the first planarization insulating film 305, corresponding to each of the R, G, and B colors. A second planarization insulating film 309 is formed so as to cover end portions of the anode layers 306, 307, and 308, and a white organic EL layer 310 and a cathode layer 311 are laminated thereon in this order.

Furthermore, a glass substrate 312 covers the cathode layer 311, and the glass substrate 312 and the glass substrate 300 are attached at their edges, so that the white organic EL layer 310 is enclosed therein.

[0010] Here, the reason to provide the second planarization insulating film 309 is that the distance between the anode layers 306, 307, and 308 and the cathode layer 311 becomes small without the second planarization insulating film 309 and may cause a short circuit. The second planarization insulating film 309 is formed with openings except above the end portions of the anode layers 306, 307, and 308, and the white organic EL layer 310 is in contact with the anode layers 306, 307, and 308 exposed in the openings.

[0011] The organic EL display device of this type is described in a Japanese Patent Application Publication No. Hei 11-251059.

[0012] However, the organic EL display device employing the described structure of the white organic EL layer and the color filter layers has following problems. Firstly, since the first planarization insulating film 305 is formed on the R color filter layer 302, the G color filter layer 303, and the B color filter layer 304, a manufacturing cost increases accordingly. This can be solved by eliminating the first planarization insulating film 305 by using the color filter layers as the first planarization insulating film 305. In this case, the adjacent color filter layers need to overlap each other for planarization and for increasing an aperture ratio. However, since the step height at the overlapping portion of the color filter layers becomes large, a display defect may occur by a cut in the organic EL layer, moisture absorption at the step portion, and so on.

[0013] Secondly, as the first planarization insulating film 305, organic resin such as acrylic resin having a thickness of 2 to 3 micrometers must be used for planarization. However, since the organic resin has high moisture absorbency, it can have an adverse effect on the organic EL layer which is sensitive to moisture, causing a display defect.

## SUMMARY OF THE INVENTION

[0014] The invention provides a color electroluminescent display device that includes a plurality of color pixels and a plurality of color filter layers provided for the color pixels on an insulating substrate. Each of the color filter layers allows a transmission of light of a color of a corresponding color pixel. The display device also includes an anode layer formed on each of the color filter layers, a white electroluminescent layer formed on the anode layers, and a cathode layer formed on the white electroluminescent layer. End portions of the color filter layers are tapered, and the tapered end portions of adjacent color filter layers overlap each other. A thin planarization insulating film may be formed directly on the color filter layers in addition to another planarization insulating film that covers end portions of the anode layers.

## BRIEF DESCRIPTION OF THE DRAWINGS

[0015] FIG. 1 is a cross-sectional view of an organic EL display device of an embodiment of the invention.

[0016] FIGS. 2A, 2B, 2C, and 2D are cross-sectional views of processing steps of color filter layers of the display device of FIG. 1.

[0017] FIG. 3 is a cross-sectional view of a modified organic EL display device of the embodiment of the invention.

[0018] FIG. 4 is an equivalent circuit diagram of the organic EL display device of the embodiment of the invention.

[0019] FIG. 5 is a cross-sectional view of a conventional organic EL display device.

[0020] FIG. 6 is a cross-sectional view of another conventional organic EL display device.

#### DETAILED DESCRIPTION OF THE INVENTION

[0021] An embodiment of the invention will be described with reference to the drawings. FIG. 1 is a cross-sectional view showing a pixel of an organic EL display device of the embodiment of the invention. In an actual organic EL display device, a plurality of the pixels is arranged in a matrix.

[0022] An insulating film 2 made of SiO<sub>2</sub> as a substrate is formed on a glass substrate 1. An R color filter layer 3, a G color filter layer 4, and a B color filter layer 5 are formed adjacent each other on the insulating film 2. Each of these color filter layers transmits light having a predetermined wavelength corresponding to each of R, G, and B colors, which is irradiated from a white organic EL layer 10. Although not shown, an organic EL element driving TFT and a pixel selecting TFT are formed under these color filter layers.

[0023] The R color filter layer 3, the G color filter layer 4, and the B color filter layer 5 also serve as a first planarization insulating film, such as the one 202 in FIG. 5. End portions of the color filter layers are overlapped for planarization. The end portions of the color filter layers are formed in a tapered shape so as to reduce a step height H2 at an overlapping portion. For example, the both end portions of the R color filter layer 3 are formed in a tapered shape, and one of the end portions of the G color filter layer 4 is formed to cover one of the end portions of the R color filter layer 3. Furthermore, the both end portions of the B color filter layer 5 are formed to respectively cover the end portion of the R color filter layer 3 and the end portion of the G color filter layer 4.

[0024] A conventional planarization insulating film is not formed on these color filter layers, but anode layers 6, 7, and 8 are formed directly on the R color filter layer 3, the G color filter layer 4, and the B color filter layer 5, respectively. Furthermore, a second planarization insulating film 9 is formed to cover end portions of the anode layers 6, 7, and 8, and a white organic EL layer 10 and a cathode layer 11 are laminated thereon in this order. A glass substrate 30 covers the cathode layer 11, and the glass substrate 30 and the glass substrate 1 are attached at their edges to enclose the white organic EL layer 10 therein.

[0025] The reason to provide the second planarization insulating film 9 is the same as the conventional art, that is, the distance between the anode layers 6, 7, and 8 and the cathode layer 11 becomes small without the second planarization insulating film 9 so that a short circuit can occur between the anode layers 6, 7, and 8 and the cathode layer

11. Openings are formed in the second planarization insulating film 9 except above the end portions of the anode layers 6, 7, and 8. The white organic EL layer 10 is formed on the anode layers 6, 7, and 8 exposed in the openings, being in contact therewith.

[0026] A forming method of the color filter layers will be described with reference to FIGS. 2A, 2B, 2C, and 2D. Here, a forming method of the R color filter layer 3 and the G color filter layer 4 will be described. As shown in FIG. 2A, the R color filter material layer 3a made of a negative photoresist containing a predetermined pigment is coated on the whole surface of the insulating film 2 serving as a substrate formed on the glass substrate 1. Then, the R color filter material layer 3a is exposed to light through predetermined masks 12. When the R color filter material layer 3a undergoes next development treatment, as shown in FIG. 2B, a portion of the R color filter material layer 3a which is exposed to light remains to form the R color filter layer 3. The R color filter layer 3 is formed by this exposure and development process, having tapered portions at its ends. This is because that the R color filter material layer 3a receives light beyond the area corresponding to the opening of the mask 12 with an intensity that is smaller than that of the central portion of the mask and is gradually decreasing.

[0027] Next, as shown in FIG. 2C, a G color filter material layer 4a made of a negative photoresist containing a predetermined pigment is coated on the whole surface. The G color filter material layer 4a is exposed to light through predetermined masks 13. When the G color filter material layer 4a undergoes next development treatment, as shown in FIG. 2D, a portion of the G color filter material layer 4a which is exposed to light remains to form the G color filter layer 4. By positioning the masks 13 as shown in FIG. 2D, the end portion of the G color filter layer 4 overlaps the end portion of the R color filter layer 3.

[0028] The end portion of the R color filter layer 3 is formed in a tapered shape. The end portion of the G color filter layer 4 has a tapered shape and becomes gradually thinner toward its end. Therefore, a step height H2 of an overlapping portion of the G color filter layer 4 and the R color filter layer 3 is reduced. The forming method of the B color filter layer 5 is the same as this.

[0029] Here, the less the step height H2 of the overlapping portion of the R, G, and B color filter layers is, the better the display performs. However, for preventing a cut in the white organic EL layer 9 formed above the R, G, and B color filter layers, which can be caused by the step height H2, when a film thickness of the white organic EL layer 9 is H1, it is preferable that H1 is larger than H2. In this embodiment, both end portions of the B color filter layer 5 are formed to cover the end portions of the adjacent R color filter layer 3 and G color filter layer 4, respectively.

[0030] For minimizing the step height H2 of the overlapping portion of the color filter layers, the color filter layers are preferably formed in a decreasing order of thickness. For example, when the thicknesses of the R color filter layer 3, the G color filter layer 4, and the B color filter layer 5 are T1, T2, and T3, respectively, it is preferable that T1 is larger than T2 and T2 is larger than T3. In this case, the R color filter layer 3, the G color filter layer 4, and the B color filter layer 5 are formed in this order.

[0031] Accordingly, in this embodiment, the R color filter layer 3, the G color filter layer 4, and the B color filter layer

**5** serve as the first planarization insulating film. However, as shown in **FIG. 3**, the first planarization insulating film **20** can be further formed on these color filter layers. This first planarization insulating film **20** can be formed thinner than the conventional art since the planarization is already realized to some extent by the R color filter layer **3**, the G color filter layer **4**, and the B color filter layer **5**. A preferable film thickness is between 200 nm and 300 nm.

[0032] Furthermore, since the first planarization insulating film **20** is thin, the first planarization insulating film **20** can be formed of an inorganic insulating film having low absorptivity by a PCVD (plasma-activated chemical vapor deposition) method. It is preferable to employ a silicon oxide film, a TEOS film, or a silicon nitride film as the inorganic insulating film.

[0033] Next, an equivalent circuit of the described organic EL display device and its operation will be described. **FIG. 4** is an equivalent circuit diagram of the organic EL display device, showing a pixel formed in a periphery of a gate signal line **50** at an n-th row and a drain signal line **60** at an m-th column.

[0034] The gate signal line **50** for supplying a gate signal Gn and the drain signal line **60** for supplying a drain signal, that is, a video signal Dm cross each other. An organic EL element **120**, a TFT **100** for driving the organic EL element **120**, and a TFT **110** for selecting a pixel are formed in a periphery of an intersection of the both signal lines **50** and **60**.

[0035] A drive source **105** is connected with a drain **100d** of the organic EL element driving TFT **100**, and supplies a positive drive voltage PVdd. A source **100s** is connected with an anode **121** of the organic EL element **120**.

[0036] A gate **110g** of the selecting TFT **110** for selecting a pixel is connected with the gate signal line **50** and supplied with a gate signal Gn. A drain **110d** is connected with the drain signal line **60** and supplied with the video signal Dm. The source **110s** of the selecting TFT **110** is connected with the gate **100g** of the driving TFT **100**. Here, the gate signal Gn is outputted from a gate driver circuit (not shown). The video signal Dm is outputted from a drain driver circuit (not shown).

[0037] The organic EL element is made of the anode **121**, a cathode **122**, and an emissive layer **123** formed between the anode **121** and the cathode **122**. The cathode **122** is connected with a common source **140** for supplying a negative common voltage CV.

[0038] Furthermore, the gate **100g** of the driving TFT **100** is connected with a storage capacitor **130**. That is, one electrode of the storage capacitor **130** is connected with the gate **100g**, and another electrode thereof is connected with the storage capacitor electrode **131**. The storage capacitor **130** is provided for storing the video signal of the pixel for one field period by storing electric charge corresponding to the video signal Dm.

[0039] An operation of the EL display device having the described structure will be described as follows. When the gate signal Gn becomes high level for one horizontal period, the selecting TFT **110** turns on. Then, the video signal Dm is applied from the drain signal line **60** to the gate **100g** of the driving TFT **100** through the selecting TFT **110**. In

response to the video signal Dm supplied to the gate **100g**, conductance of the driving TFT **100** changes. The drive electric current corresponding to the conductance is supplied from the drive source **105** to the organic EL element **120** through the driving TFT **100**. Accordingly, luminance of the organic EL element **120** is controlled.

[0040] Although colors of the color pixels and the color filter layers are R (red), G (green), and B (blue) in this embodiment, the colors may be yellow or magenta. Furthermore, the "white EL" is mainly white, but may be reddish or bluish.

What is claimed is:

1. A color electroluminescent display device comprising:
  - a plurality of color pixels;
  - a plurality of color filter layers provided for the color pixels on an insulating substrate, each of the color filter layers allowing a transmission of light of a color of a corresponding color pixel;
  - an anode layer formed above each of the color filter layers;
  - a white electroluminescent layer formed on the anode layers; and
  - a cathode layer formed on the white electroluminescent layer,
 wherein end portions of the color filter layers are tapered, and the tapered end portions of adjacent color filter layers overlap each other.
2. The color electroluminescent display device of claim 1, wherein a step height at an overlapping portion of the color filter layers is smaller than a thickness of the white electroluminescent layer.
3. The color electroluminescent display device of claim 1, wherein the color filter layers have different thicknesses and end portions of thinner color filter layers are disposed above end portions of thicker color filter layers.
4. A color electroluminescent display device having a plurality of color pixels, comprising:
  - a plurality of color filter layers provided for the color pixels on an insulating substrate, each of the color filter layers allowing a transmission of light of a color of a corresponding color pixel;
  - a planarization insulating film formed on the color filter layers;
  - anode layers formed on the planarization insulating film;
  - a white electroluminescent layer formed on the anode layers; and
  - a cathode layer formed on the white electroluminescent layer,
 wherein end portions of the color filter layers are tapered, and the tapered end portions of adjacent color filter layers overlap each other.
5. The color electroluminescent display device of claim 4, wherein a step height at an overlapping portion of the color filter layers is smaller than a thickness of the white electroluminescent layer.
6. The color electroluminescent display device of claim 4, wherein the color filter layers have different thicknesses and

end portions of thinner color filter layers are disposed above end portions of thicker color filter layers.

**7.** The color electroluminescent display device of claim 4, wherein the planarization insulating film comprises an inorganic insulating film.

**8.** The color electroluminescent display device of claim 7, wherein the inorganic insulating film is a silicon oxide film, a TEOS film or a silicon nitride film.

**9.** A color electroluminescent display device having a plurality of color pixels, comprising:

a plurality of color filter layers provided for the color pixels on an insulating substrate, each of the color filter layers allowing a transmission of light of a color of a corresponding color pixel;

a first planarization insulating film formed on the color filter layers;

anode layers formed on the first planarization insulating film;

a second planarization insulating film formed so as to cover end portions of the anode layers;

a white electroluminescent layer formed on the anode layers; and

a cathode layer formed on the white electroluminescent layer;

wherein end portions of the color filter layers are tapered, and the tapered end portions of adjacent color filter layers overlap each other.

**10.** The color electroluminescent display device of claim 9, wherein a step height at an overlapping portion of the color filter layers is smaller than a thickness of the white electroluminescent layer.

**11.** The color electroluminescent display device of claim 9, wherein the color filter layers have different thicknesses and end portions of thinner color filter layers are disposed above end portions of thicker color filter layers.

**12.** The color electroluminescent display device of claim 9, wherein the first planarization insulating film comprises an inorganic insulating film.

**13.** The color electroluminescent display device of claim 12, wherein the inorganic insulating film is a silicon oxide film, a TEOS film or a silicon nitride film.

**14.** A color electroluminescent display device comprising:

a first pixel of a first color;

a second pixel of a second color disposed adjacent the first pixel;

a first color filter layer provided for the first pixel and allowing a transmission of light of the first color, the first color filter layer having a tapered end portion;

a second color filter layer provided for the second pixel and allowing a transmission of light of the second color, the second color filter layer having a tapered end portion;

a first anode layer formed on the first color filter layer;

a second anode layer formed on the second color filter layer;

a white electroluminescent layer formed on the first and second anode layers; and

a cathode layer formed on the white electroluminescent layer,

wherein the tapered end portion of the first color filter layer is disposed over the tapered end portion of the second color filter layer.

**15.** The color electroluminescent display device of claim 14, wherein a thickness of the first color filter layer is smaller than a thickness of the second color filter layer.

\* \* \* \* \*

专利名称(译)	电致发光显示装置		
公开(公告)号	<a href="#">US20040207321A1</a>	公开(公告)日	2004-10-21
申请号	US10/758596	申请日	2004-01-16
[标]申请(专利权)人(译)	三洋电机株式会社		
申请(专利权)人(译)	SANYO ELECTRIC CO., LTD.		
当前申请(专利权)人(译)	SANYO ELECTRIC CO., LTD.		
[标]发明人	NISHIKAWA RYUJI MAEDA KAZUYUKI		
发明人	NISHIKAWA, RYUJI MAEDA, KAZUYUKI		
IPC分类号	H05B33/12 G09F9/30 H01J1/62 H01L27/32 H01L51/50 H05B33/02 H05B33/14 H05B33/20 H05B33/22		
CPC分类号	H01L27/3244 H01L27/322		
优先权	2003012380 2003-01-21 JP		
其他公开文献	US7545095		
外部链接	<a href="#">Espacenet</a> <a href="#">USPTO</a>		

摘要(译)

本发明涉及一种电致发光显示装置，其中不需要使用第一平坦化绝缘膜，从而降低制造成本，并且防止由有机EL层的切割或台阶部分的吸湿引起的显示缺陷。形成R滤色器层，G滤色器层和B滤色器层，使得相邻的R，G和B滤色器层的端部彼此重叠。R滤色器层，G滤色器层和B滤色器层用作第一平坦化绝缘膜。为了平坦化，滤色器层的端部彼此重叠。为了减小重叠部分的台阶高度，滤色器的端部形成为锥形。

